

GL-2

Integrally Geared Single Stage Blower



LONE STAR
TURBO

MODEL GL-2

Standard Specifications

Gas	Air, Steam, H2S, Biogas, Fuel Gas, CO2, N2, LNG, Custom
Flow Range	100% to 35% of Rated Flow with Combination Control
Pressure Range	Up to 30 PSIG / 2 bar
Maximum Case Pressure	50 PSIG / 3.5 bar
Stages	Single Stage
Drive Type	Direct Coupled
Power Driver Options	Electric Motor, Steam Turbine, Combustion Engine
Gearbox	Helical Gear Set
Cooling Lubricant	Lubricant Cooling (Air or Liquid)
Lubrication Options	Pressurized Oil
Bearings	Pinion - Tilt Pad Journal, Drive Journal
Enclosure	Optional
Sound Level	Job Specific
Sound Level with Enclosure	Job Specific
Filtration Rating (std)	99% at 2 micron, or as required
Seals Air	Labyrinth Type

Standard Materials of Construction

Casing	Grey Iron GG25, Ductile, ASTM A536, A48 or Equal
Bearings	ANSI 5140 Steel, Babbitted, 40CR Alloy Casing
Impeller	AlCu2MgNi Alloy (annodized), 17-4PH, Titanium, Inconel
Inlet Guide Vanes	Stainless Steel 316
Discharge Diffuser Vanes	Stainless Steel 316
Gears	AISI 8620, Steel 10CrNiMo to AGMA 12/13
Shaft	Steel 10CrNiMo
Seals Air	ASTM B86 Z25631 Zinc Alloy Aluminum
Seals Gas	ASTM C695 Molded Graphite
Blower Base Skid	ASTM A36 Structural Steel
Isolation Pads	St. SIS 1312 inertial dampening with rubber hardness 60
Finish	2 Part Epoxy Lone Star Blue RAL5005
Enclosure	Aluminum, Galvanized Steel, Stainless

Optional Testing & Certifications

API	API 617, API 672, API 614
Electrical	UL 508A, CE, CSA
Hazardous Location	ATEX, Class1 - Division 1- Division 2, Zone 0-2
Balancing	ISO 1940 - G2.5, ~4W/N API
Noise Level	OSHA 1910.95, ISO 2151:2004
Performance	ASME PTC-10, PTC-13, ISO 5389
Hydro Testing	1.5 Time MAWP
Overspeed Testing	Optional
Positive Material ID	XRF, OES, Material Certification
NACE Compliance	Optional
Special Coatings	Optional

Service

Air, Gas, Pressure, Vacuum

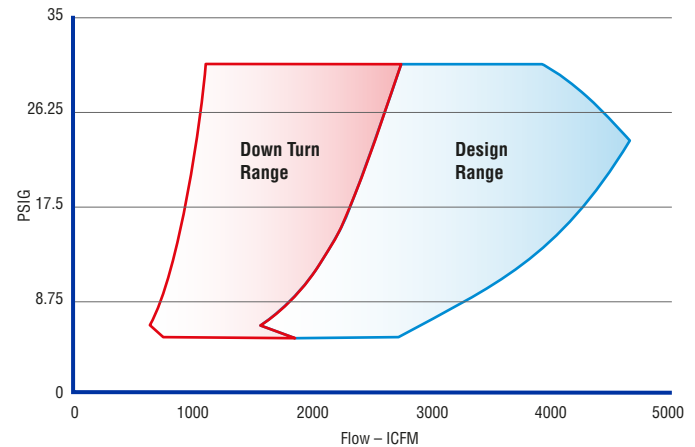

Control Options

Control Methods	Variable Inlet and Discharge Guide Vane, speed control, blow off, or combination
Local Controller	sLOC™ Standard - Custom for Allen Bradley, Modicon, Siemens or Other
HMI	sLOC™ Standard or Custom HMI
Remote Monitoring	sLINK™ or Custom
Control Set Points	Pressure, Flow, Power, Custom Input



REVISION HISTORY			
REV	DESCRIPTION	DATE	APPROVED
1	AIR OUTLET VERTICALLY UP	5/28/2016	
2	REQUIRED FROM 63.3-WX-03 TO 63.3-WX-01 CONVERTED FROM mm TO INCHES	7/9/2016	

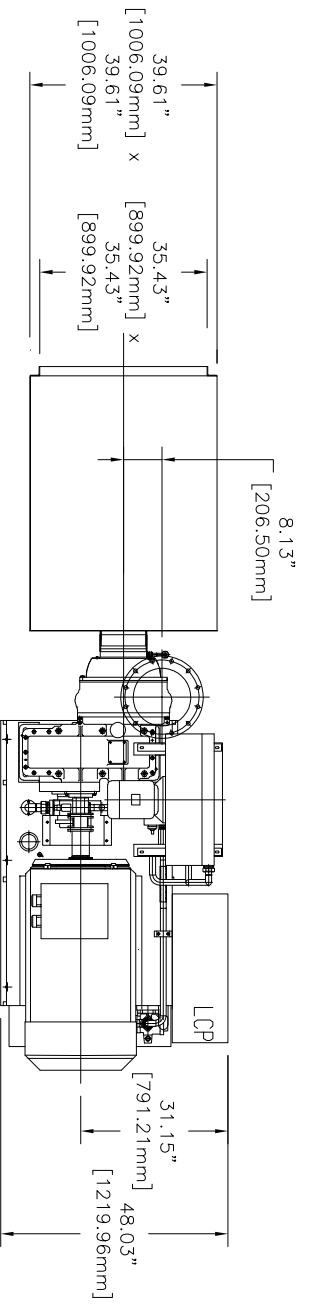
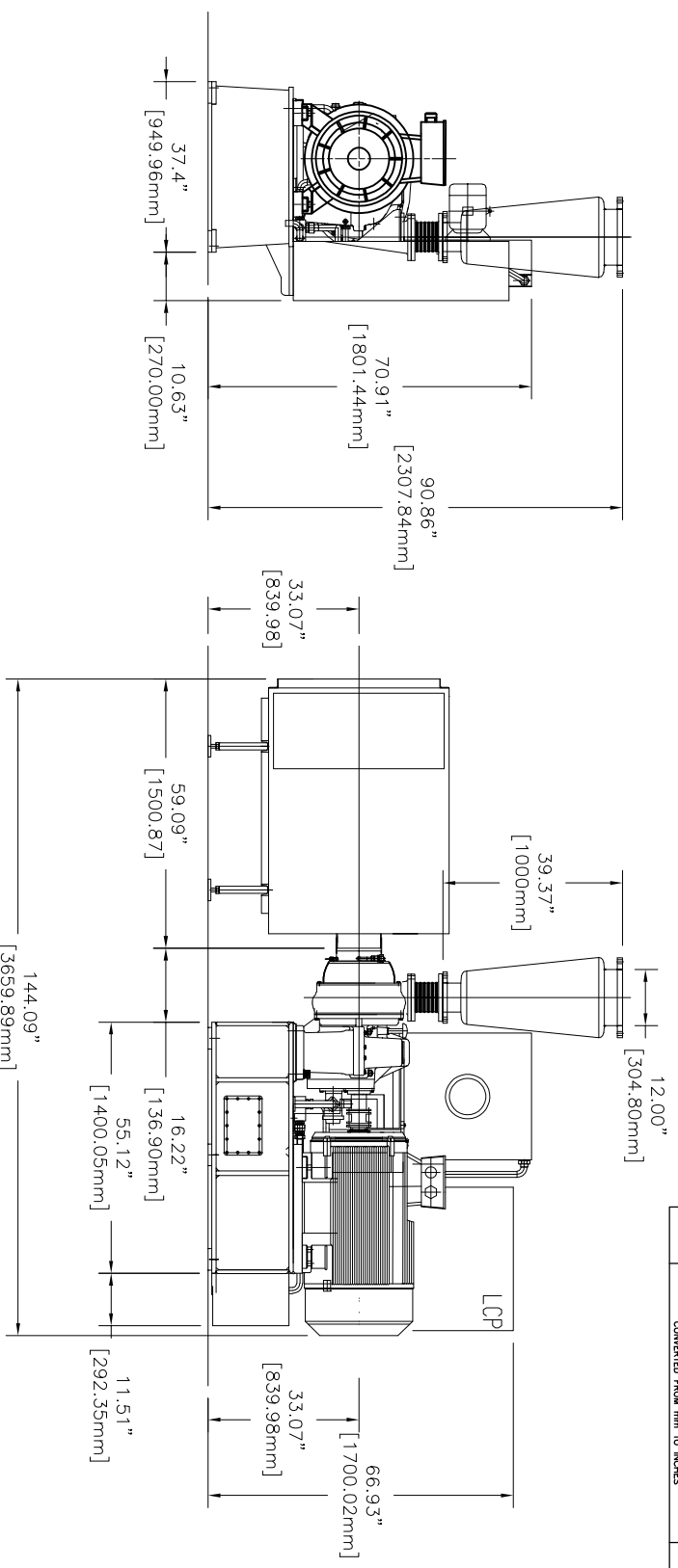

- NOTES:
1. BLOWER OUTLET ANGLE ADJUSTABLE EVERY 15° RADIALLY
 2. BLOWER INSTALLED BY EXPANSION BOLTS.

DIMENSIONS & WEIGHTS BY MOTOR SIZE			
MOTOR	"A"	"B"	WEIGHT (LBS)
100HP	55.12	144.09	5,247
125HP	55.12	144.09	5,291

DRAWING IS FOR REFERENCE ONLY UNLESS SPECIFIED AS RELEASED.		APPROVALS		 <p>LONE STAR BLOWER</p>
DRAWN	BW	07/05/2016		
CHECK				
ENGINEER				
MANUFACTURING		CONTROL		TITLE
APPROVED		SCALE		GL-2 GEARED TURBO GENERAL ASSEMBLY 12" CONE
		SIZE		DWG NUMBER
		A		GL2-WX-01
		SHEET		REV
		1 OF 1		02

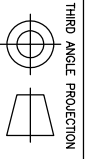

REVISION HISTORY			
REV	DESCRIPTION	DATE	APPROVED
1	AIR OUTLET VERTICALLY UP	5/28/2016	
2	REMOVED FROM GL2-WX-01 TO GL2-WX-01 CONVERTED FROM mm TO INCHES	7/9/2016	

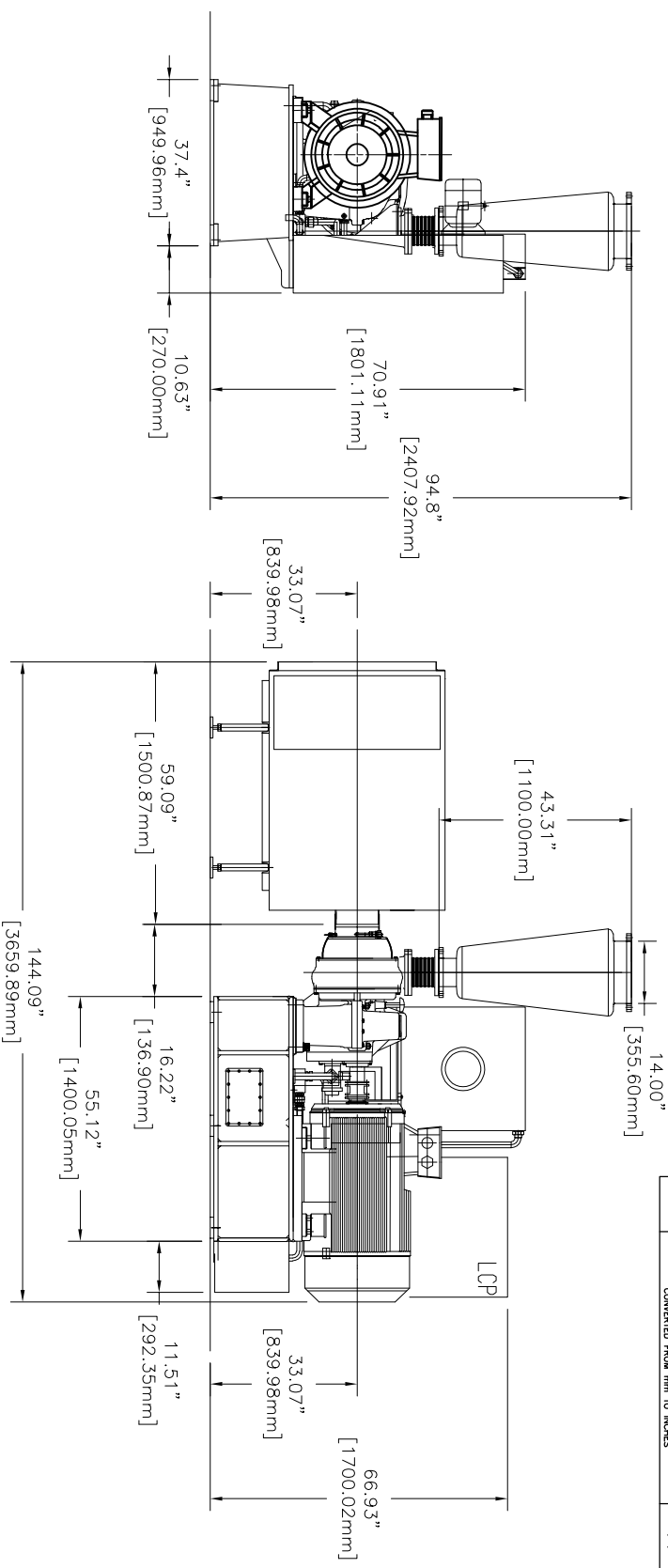

- NOTES:
- BLOWER OUTLET ANGLE ADJUSTABLE EVERY 15° RADIALLY
 - BLOWER INSTALLED BY EXPANSION BOLTS.

DIMENSIONS & WEIGHTS BY MOTOR SIZE			
MOTOR	"A"	"B"	WEIGHT (LBS)
100HP	55.12	144.09	5,247
125HP	55.12	144.09	5,291

DRAWING IS FOR REFERENCE ONLY UNLESS SPECIFIED AS RELEASED.		APPROVALS		TITLE	
DRAWN	BW	07/05/2016	LONE STAR BLOWER		
CHECK			GL-2 GEARED TURBO		
ENGINEER			GENERAL ASSEMBLY 14" CONE		
MANUFACTURING			SIZE	DWG NUMBER	REV
CONTROL			A	GL2-WX-01	02
APPROVED			SCALE	SHEET 1 OF 1	

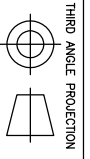

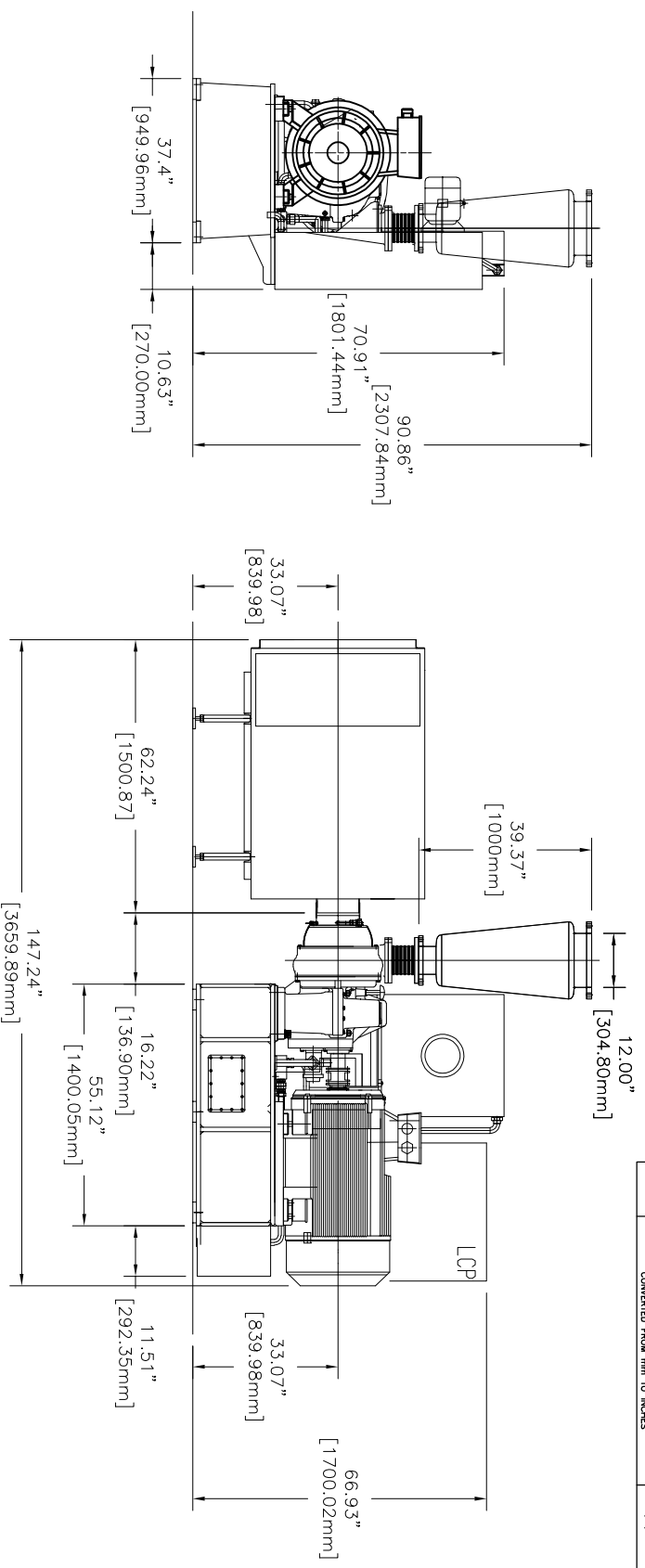

REVISION HISTORY			
REV	DESCRIPTION	DATE	APPROVED
1	AIR OUTLET VERTICALLY UP	5/28/2016	
2	REMOVED FROM GL2-WX-01 TO GL2-WX-01 CONVERTED FROM mm TO INCHES	7/9/2016	

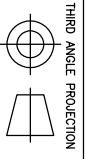

- NOTES:
- BLOWER OUTLET ANGLE ADJUSTABLE EVERY 15° RADIALY.
 - BLOWER INSTALLED BY EXPANSION BOLTS.

DIMENSIONS & WEIGHTS BY MOTOR SIZE			
MOTOR	"A"	"B"	WEIGHT (LBS)
150HP	55.12	147.24	5,666



DRAWING IS FOR REFERENCE ONLY UNLESS SPECIFIED AS RELEASED.		APPROVALS		 <p>LONE STAR BLOWER</p>
DRAWN	BW	07/05/2016		
CHECK				
ENGINEER				
MANUFACTURING		CONTROL		
APPROVED		APPROVED		
TITLE		SIZE		REV
GL-2 GEARED TURBO		A		02
GENERAL ASSEMBLY 12" CONE		GL2-WX-01		
SCALE		SHEET		
		1 OF 1		

REVISION HISTORY			
REV	DESCRIPTION	DATE	APPROVED
1	AIR OUTLET VERTICALLY UP	5/28/2016	
2	REMOVED FROM GL2-WX-01 TO GL2-WX-01 CONVERTED FROM mm TO INCHES	7/9/2016	

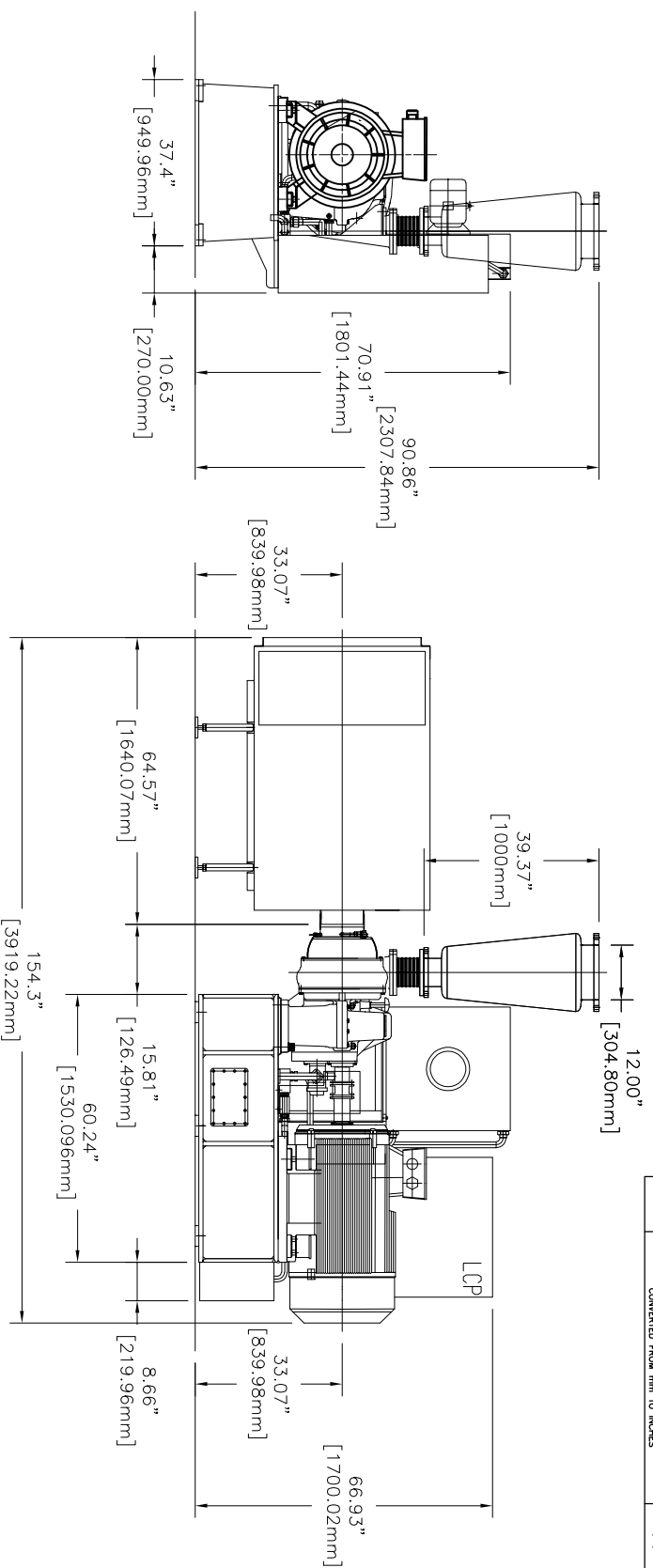

- NOTES:
1. BLOWER OUTLET ANGLE ADJUSTABLE
 2. EVERY 15° RADIALITY.
 3. BLOWER INSTALLED BY EXPANSION BOLTS.

DIMENSIONS & WEIGHTS BY MOTOR SIZE			
MOTOR	"A"	"B"	WEIGHT (LBS)
175HP	60.24	154.33	6,305
200HP	60.24	154.33	6,559
250HP	60.24	154.33	6,801
275HP	60.24	154.33	6,823

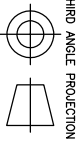
DRAWING IS FOR REFERENCE ONLY UNLESS SPECIFIED AS RELEASED.		APPROVALS		 <p>LONE STAR BLOWER</p>
DRAWN	BW	07/05/2016		
CHECK				
ENGINEER				
THIRD ANGLE PROJECTION				
MANUFACTURING				
CONTROL				
APPROVED				
TITLE		SCALE		REV
GL-2 GEARED TURBO		A		02
GENERAL ASSEMBLY 12" CONE		GL2-WX-01		
SIZE		DWG NUMBER		
A		GL2-WX-01		
SHEET 1 OF 1				

REVISION HISTORY			
REV	DESCRIPTION	DATE	APPROVED
1	AIR OUTLET VERTICALLY UP	5/28/2016	
2	REQUIRED FROM GL2-WX-01 TO GL2-WX-01 CONVERTED FROM mm TO INCHES	7/9/2016	

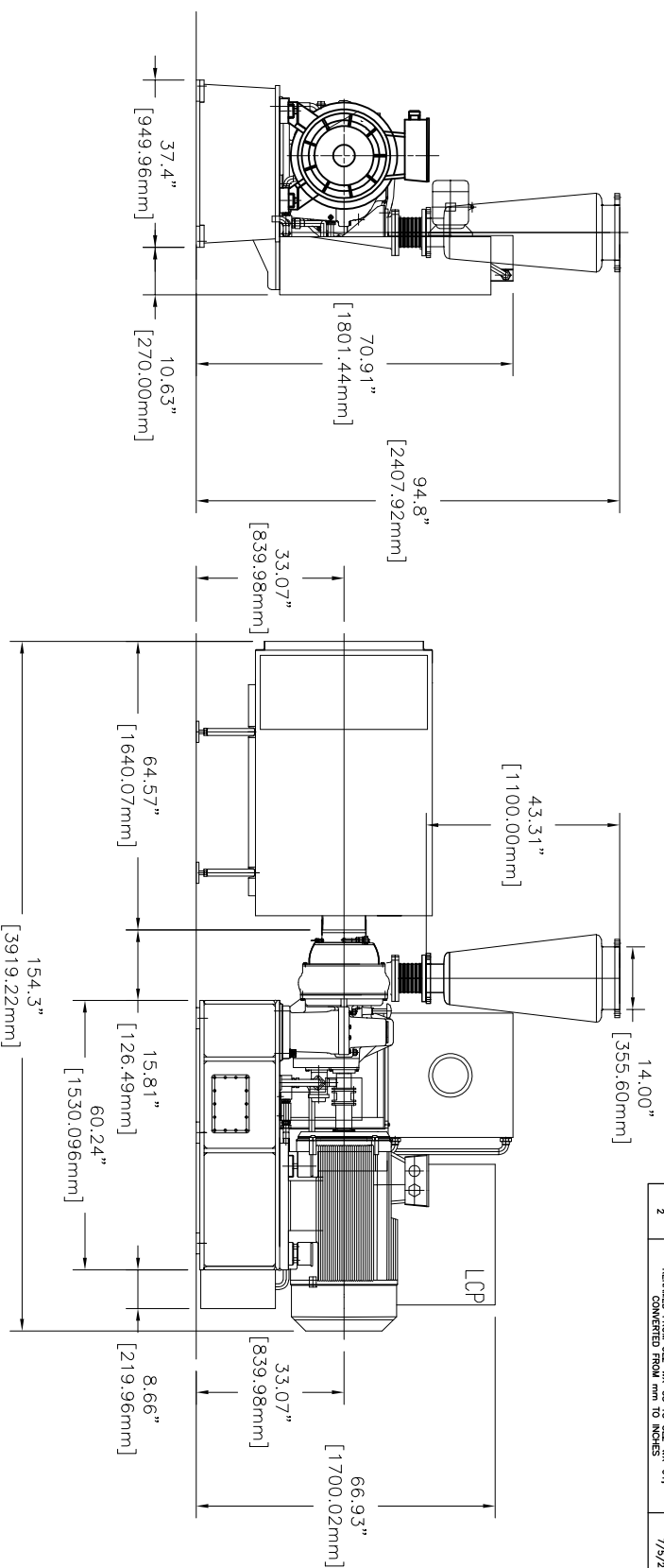

- NOTES:
- BLOWER OUTLET ANGLE ADJUSTABLE EVERY 15° RADIALY.
 - BLOWER INSTALLED BY EXPANSION BOLTS.

DIMENSIONS & WEIGHTS BY MOTOR SIZE			
MOTOR	"A"	"B"	WEIGHT (LBS)
175HP	60.24	154.33	6,305
200HP	60.24	154.33	6,559
250HP	60.24	154.33	6,801
275HP	60.24	154.33	6,823

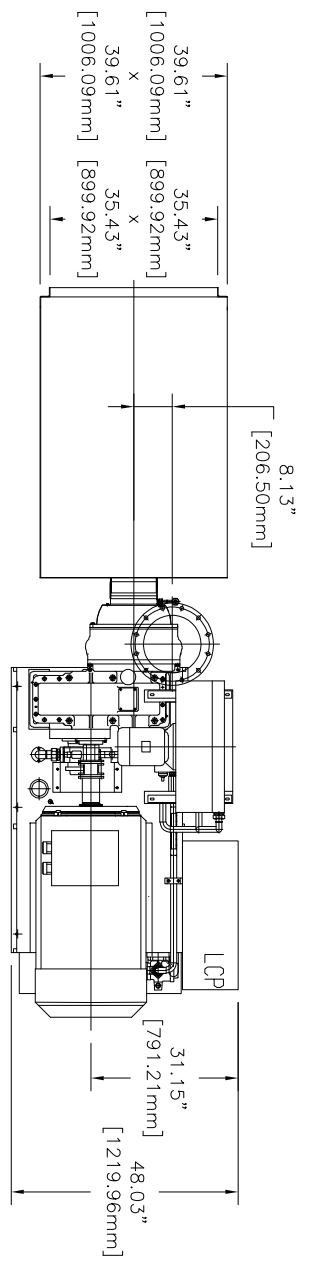

DRAWING IS FOR REFERENCE ONLY UNLESS SPECIFIED AS RELEASED.		APPROVALS	
DRAWN	BW	07/05/2016	
CHECK			
ENGINEER			
MANUFACTURING			
CONTROL			
APPROVED			

	
TITLE	
GL-2 GEARED TURBO	
GENERAL ASSEMBLY 14" CONE	
SIZE	DWG NUMBER
A	GL2-WX-01
SCALE	SHEET 1 OF 1
REV	02

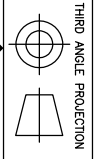

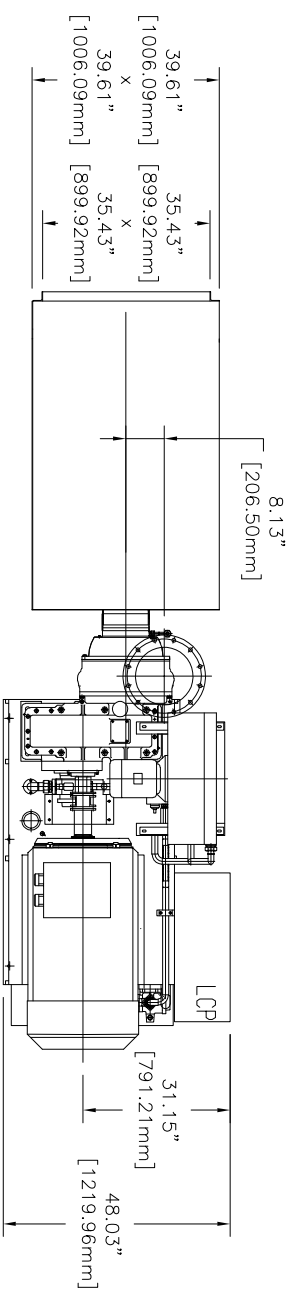
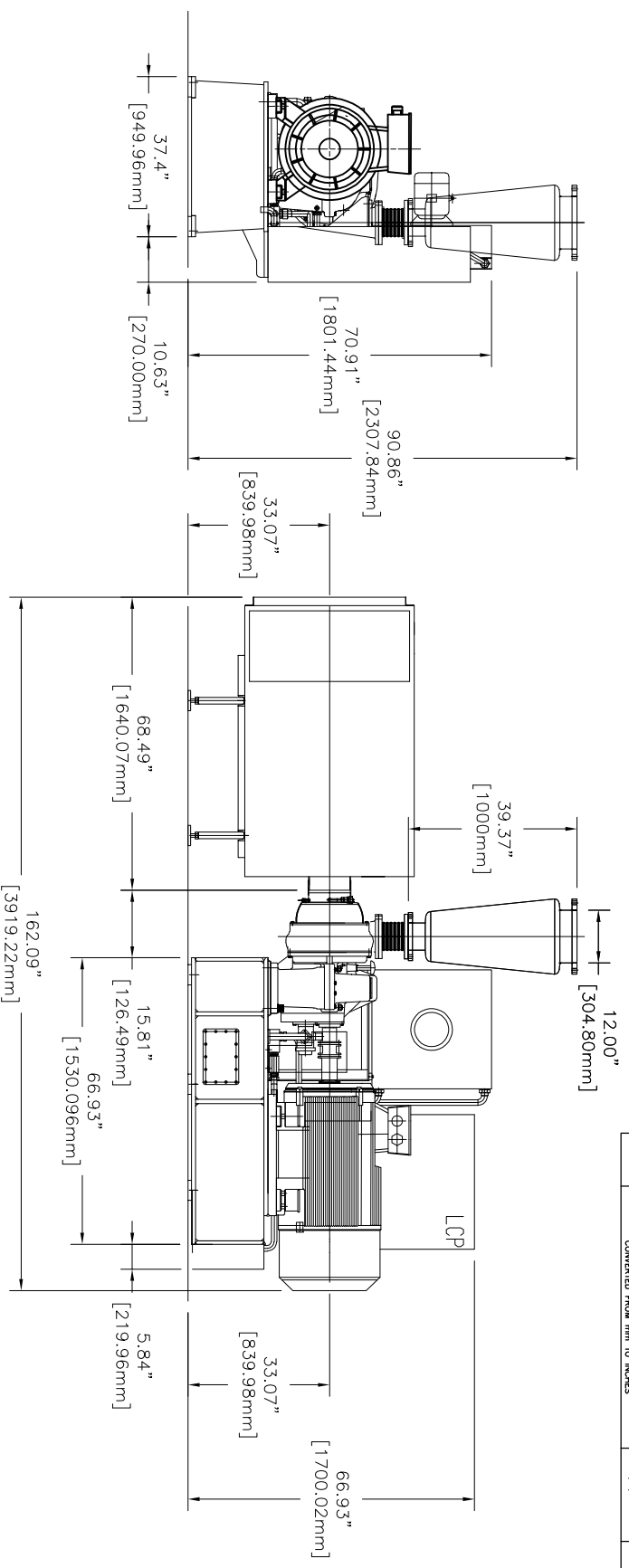

REVISION HISTORY			
REV	DESCRIPTION	DATE	APPROVED
1	AIR OUTLET VERTICALLY UP	5/28/2016	
2	REMOVED FROM GL2-WX-01 TO GL2-WX-011 CONVERTED FROM mm TO INCHES	7/9/2016	

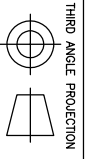

- NOTES:
1. BLOWER OUTLET ANGLE ADJUSTABLE
 2. EVERY 15° RADially
 3. BLOWER INSTALLED BY EXPANSION BOLTS.

DIMENSIONS & WEIGHTS BY MOTOR SIZE			
MOTOR	"A"	"B"	WEIGHT (LBS)
300HP	66.93	162.09	8,135
350HP	66.93	162.09	8,245



DRAWING IS FOR REFERENCE ONLY UNLESS SPECIFIED AS RELEASED.		APPROVALS		 <p>LONE STAR BLOWER</p>
DRAWN	BW	07/05/2016		
CHECK				
ENGINEER				
MANUFACTURING		TITLE		GL-2 GEARED TURBO
CONTROL		GENERAL ASSEMBLY 12" CONE		
APPROVED		SCALE	A	DWG NUMBER GL2-WX-01
		SHEET	1	OF 1
		REV		02

REVISION HISTORY			
REV	DESCRIPTION	DATE	APPROVED
1	AIR OUTLET VERTICALLY UP	5/28/2016	
2	REMOVED FROM GL2-WX-01 TO GL2-WX-01 CONVERTED FROM mm TO INCHES	7/9/2016	

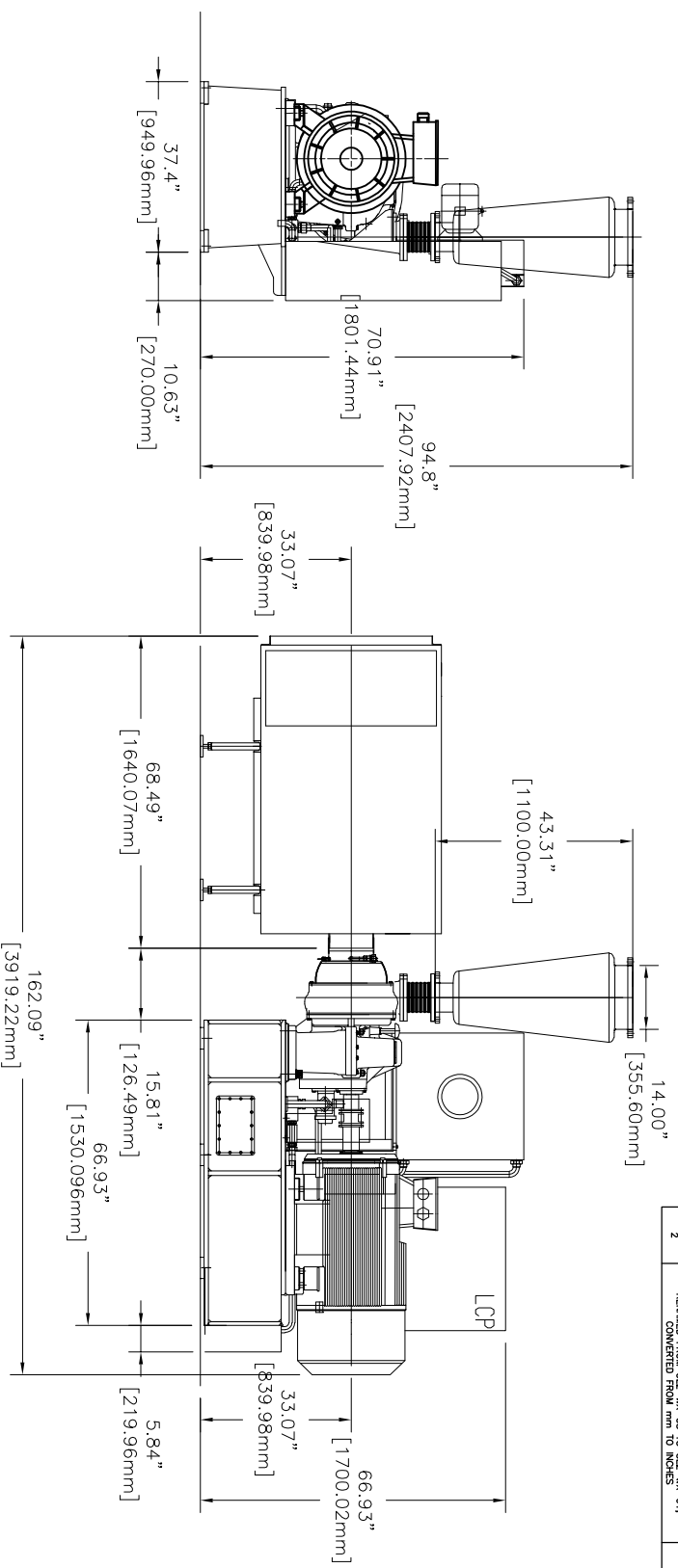

- NOTES:
- BLOWER OUTLET ANGLE ADJUSTABLE EVERY 15° RADIALLY
 - BLOWER INSTALLED BY EXPANSION BOLTS.

DIMENSIONS & WEIGHTS BY MOTOR SIZE			
MOTOR	"A"	"B"	WEIGHT (LBS)
300HP	66.93	162.09	8,135
350HP	66.93	162.09	8,245

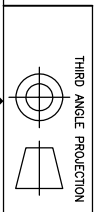

DRAWING IS FOR REFERENCE ONLY UNLESS SPECIFIED AS RELEASED.		APPROVALS		 <p>LONE STAR BLOWER</p>
DRAWN	BW	07/05/2016		
CHECK				
ENGINEER				
MANUFACTURING		CONTROL		TITLE
APPROVED				GL-2 GEARED TURBO GENERAL ASSEMBLY 14" CONE
SIZE	CAGE CODE	DWG NUMBER	REV	
A		GL2-WX-01	02	
SCALE			SHEET	1 OF 1