

# MAX250

Gearless High Speed Turbo Blower



**LONE STAR**  
TURBO

## MODEL MAX250-C080

### Standard Specifications

Gas	Air Only
Flow Range	100% to 45% of Rated Flow*
Maximum Case Pressure	35 PSIG / 2.4 bar
VFD (integral)	Vacon, KEB, Yaskawa
Stages	Single Stage
Power Driver Options	Integral Permanent Magnet Electric Motor
Cooling	Self Cooled Air Cooled
Bearings	NSTB+ Air Foil
Enclosure	Standard
Sound Level	75 dB @ 3 feet free field
Filtration Rating (std)	99% at 2 micron, or as required

### Control Options

Control Methods	Speed Control, Blow Off Control, Pressure, Flow
Local Controller	sLOC™ Standard - Custom for Allen Bradley, Modicon, Siemens or Other
HMI	sLOC™ Standard or Custom HMI
Remote Monitoring	sLINK™ or Custom
Control Set Points	Pressure, Flow, Power, Custom Input

### Standard Materials of Construction

Casing	A356 Cast Aluminum
Volute	A356 Cast Aluminum
Bearings	Inconel with Teflon, Nano Silver Coatings
Impeller	5 Axis Machined anodized 7075 Aluminum
Shaft	Titanium alloy with Sm2CO17 Magnets
Blower Base Skid	ASTM A36 Structural Steel
Isolation Pads	Adjustable Feet with Mounting Anchor
Finish	Powder Coated Cabinet

### Optional Testing & Certifications

Electrical	UL 508A, UL 1450, CSA, CE, IEEE519
Hazardous Location	Not Classified
Balancing	ISO 1940 - G2.5, ~4W/N API
Noise Level	OSHA 1910.95, ISO 2151:2004
Performance Testing	ASME PTC-10, PTC-13, ISO 5389

### Standard Options

- High and Low Ambient Temperature
- Separated Electrical and Mechanical Enclosure
- Flanged Intake
- Outdoor Enclosure
- Dual and Duplex Options
- Harmonic Filter

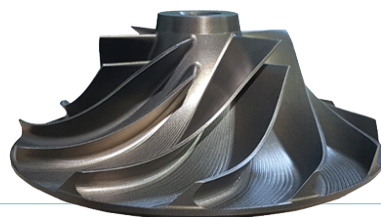

### Service

Air and Pressure

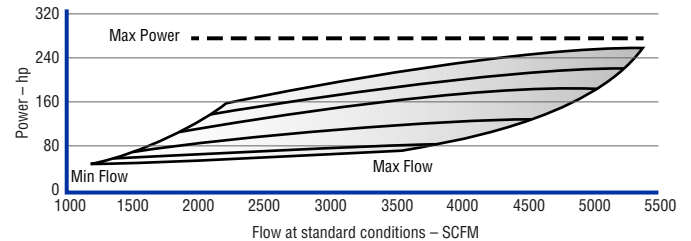
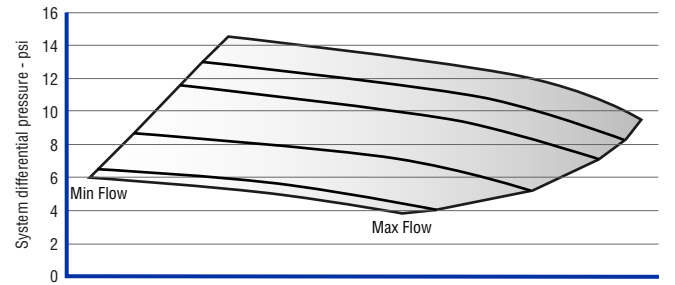

\* Information is approximate and can change without notice  
\* Performance Based on 1 Atm, 68F/20C, 36% RH and 3550 rpm

**VIEW "E-E"**  
(LOOKING DOWNWARD)

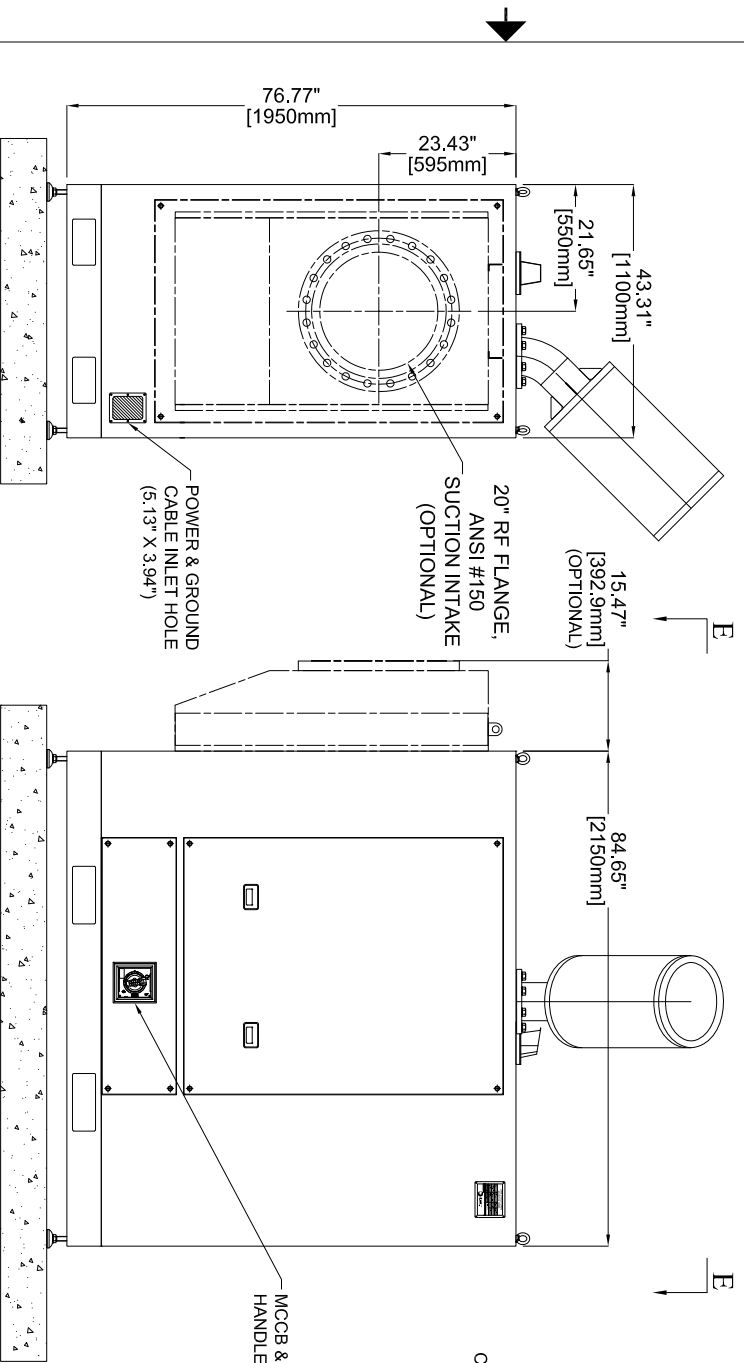
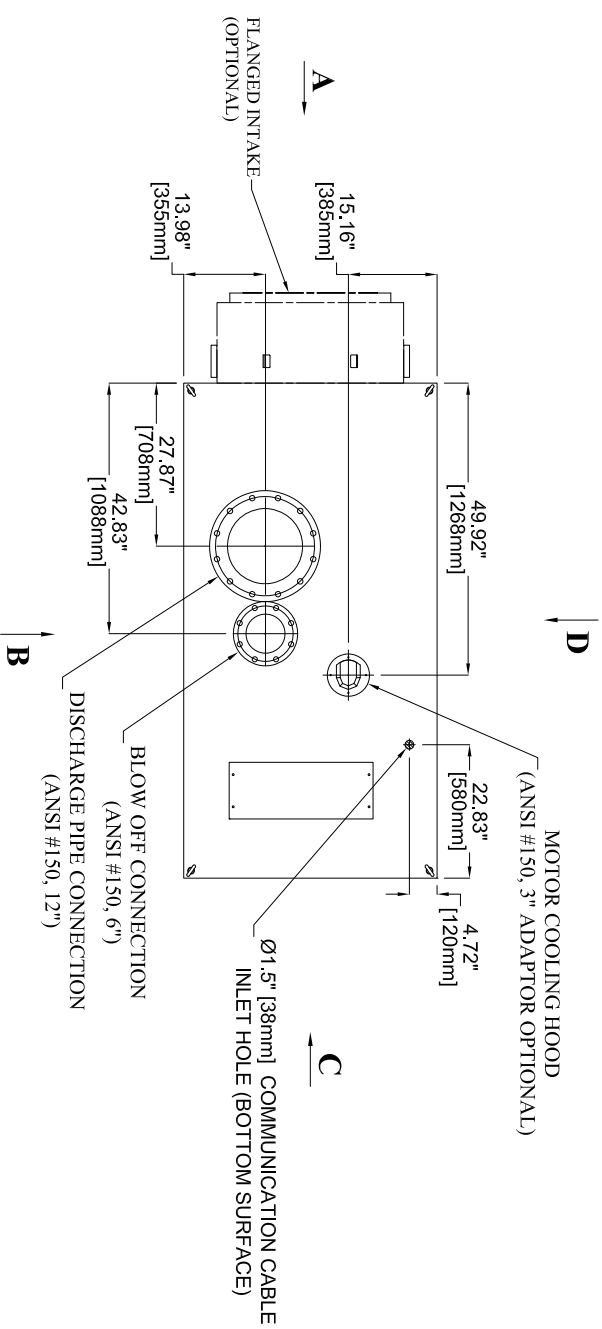

**VIEW "A"**  
(REAR SIDE)

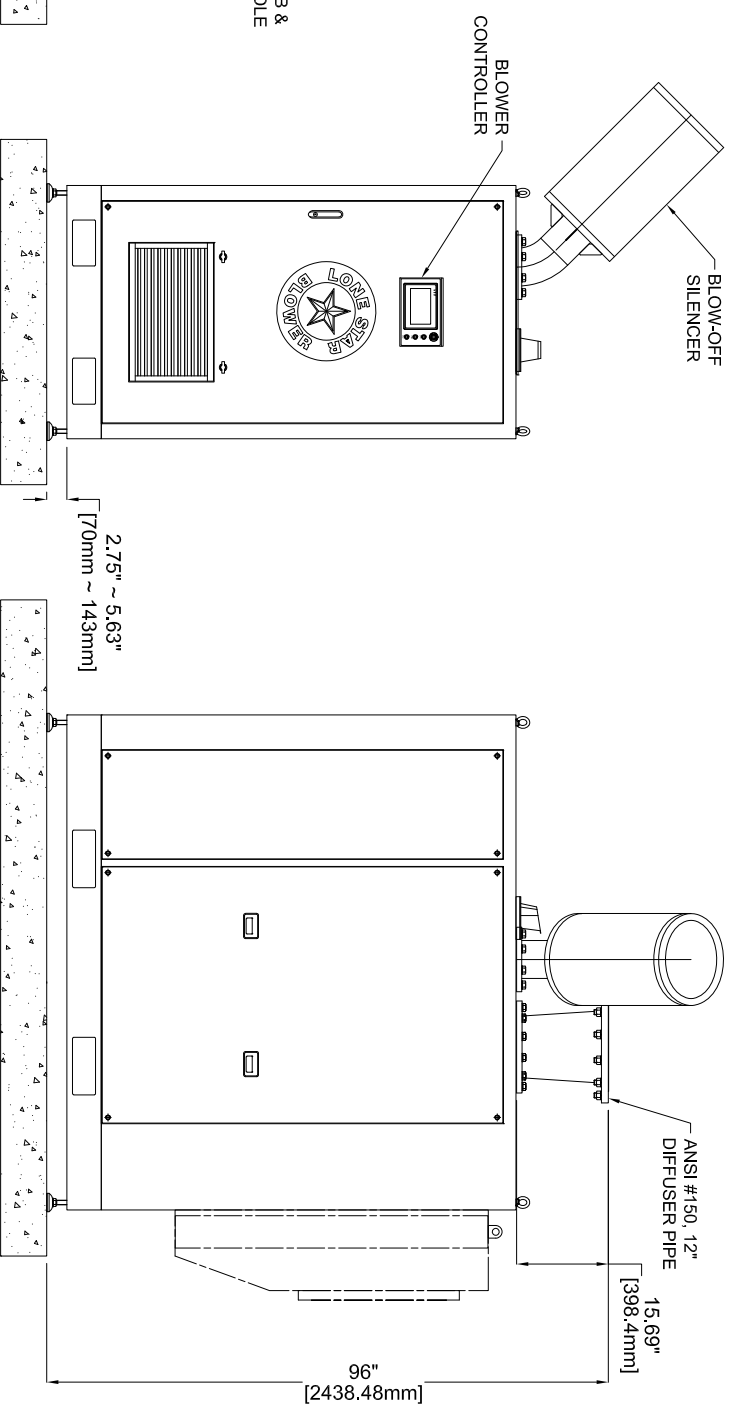

**VIEW "B"**  
(LEFT SIDE)

**VIEW "C"**  
(FRONT SIDE)

**VIEW "D"**  
(RIGHT SIDE)

REVISION HISTORY		
REV	DESCRIPTION	DATE

ALL DIMENSIONS ARE SUBJECT TO CHANGE WITHOUT NOTICE.  
PLEASE CONSULT WITH LONE STAR PRIOR TO DESIGNING AROUND PARTICULAR EQUIPMENT.

MODELS	WEIGHT
MAX250-C080~C120 LOUVER	3,086 LBS (1400 KG)
MAX250-C080~C120 FLANGED INTAKE	3,186 LBS (1445 KG)

UNLESS OTHERWISE SPECIFIED  
DO NOT SCALE

LONE STAR BLOWER PROPRIETARY RIGHTS ARE INCLUDED HEREIN. THIS INFORMATION MAY NOT BE COPIED, TRANSFERRED, OR DISCLOSED, EXCEPT AS AUTHORIZED BY LONE STAR BLOWER.

DRAWING IS FOR REFERENCE ONLY  
UNLESS SPECIFIED AS RELEASED.

APPROVALS

DRAWN JMC 06/04/2021

CHECK

ENGINEER

MANUFACTURING

CONTROL

APPROVED



TITLE  
DT SERIES

BLOWER MAX250-C080~C120

SIZE / CAGE CODE A -  
DWG NUMBER MAX250-C080~C120  
SCALE SHEET 1 OF 1

REV 0