



### Model MAX50-C100

**Service**  
Air and Pressure

### Standard Specifications

Flow Range.....	100% to 45% of Rated Flow*
Maximum Case Pressure .....	35 PSIG / 2.4 bar
VFD (integral) .....	Vacon, KEB, Yaskawa
Stages.....	Single Stage
Power Driver Options.....	Intregal Permanent Magnet Electric Motor
Cooling .....	Self Cooled Air Cooled
Bearings .....	NSTB+ Air Foil
Enclosure.....	Standard
Sound Level.....	75 dB @ 3 feet free field
Filtration Rating (std).....	99% at 2 micron, or as required

### Control Options

Control Methods .....	Speed Control, Blow Off Control, Pressure, Flow
Local Controller.....	sLOC™ Standard - Custom for Allen Bradley, Modicon, Siemens or Other
HMI.....	sLOC™ Standard or Custom HMI
Remote Monitoring .....	sLINK™ or Custom
Control Set Points .....	Pressure, Flow, Power, Custom Input

### Standard Materials of Construction

Casing.....	A356 Cast Aluminum
Volute .....	A356 Cast Aluminum
Bearings .....	Inconel with Teflon, Nano Silver Coatings
Impeller.....	5 Axis Machined anodized 7075 Aluminum
Shaft .....	Titanium alloy with Sm2C017 Magnets
Blower Base Skid .....	ASTM A36 Structural Steel
Isolation Pads.....	Adjustable Feet with Mounting Anchor
Finish.....	Powder Coated Cabinet

### Optional Testing & Certifications

Electrical.....	UL 508A, UL 1450, CSA, CE, IEEE519
Hazardous Location .....	Not Classified
Balancing.....	ISO 1940 - G2.5, ~4W/N API
Noise Level.....	OSHA 1910.95, ISO 2151:2004
Performance Testing .....	ASME PTC-10, PTC-13, ISO 5389

#### Standard Options

- High and Low Ambient Temperature
- Separated Electrical and Mechanical Enclosure
- Flanged Intake
- Outdoor Enclosure
- Dual and Duplex Options
- Harmonic Filter

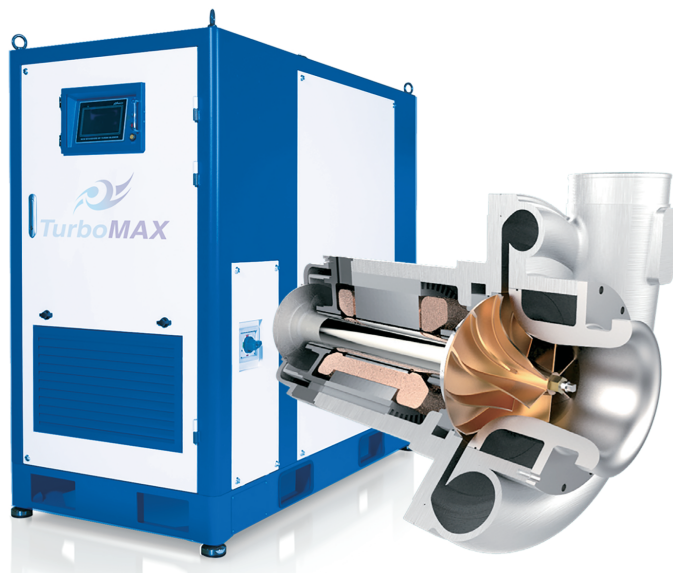
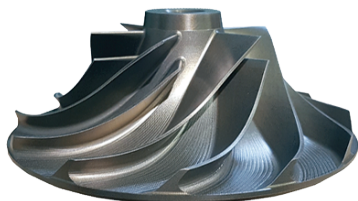

**VIEW "E-E"**  
(LOOKING DOWNWARD)

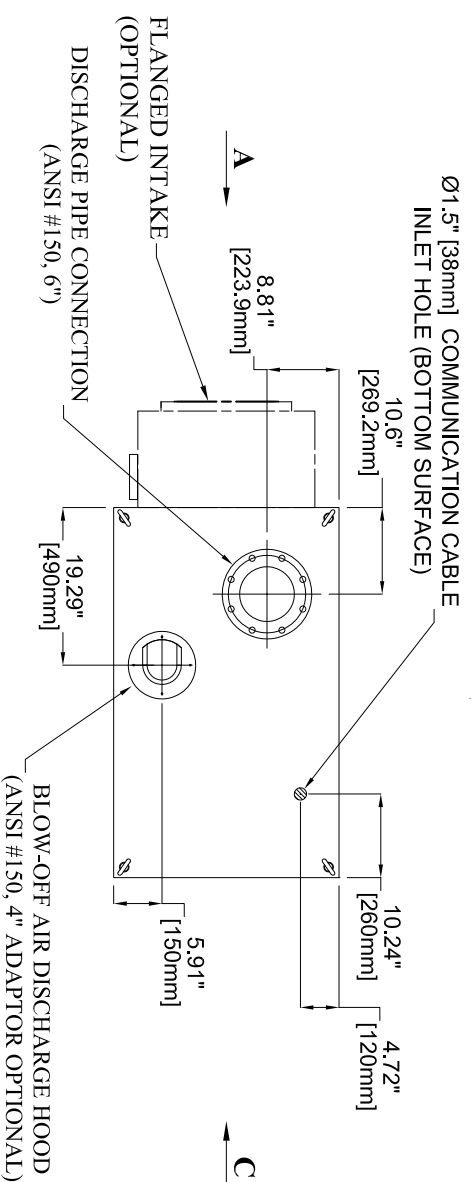

**VIEW "A"**  
(REAR SIDE)

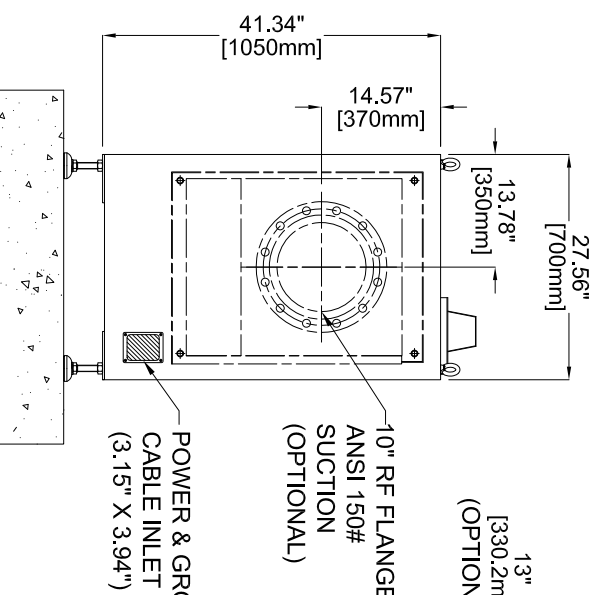

**VIEW "B"**  
(LEFT SIDE)

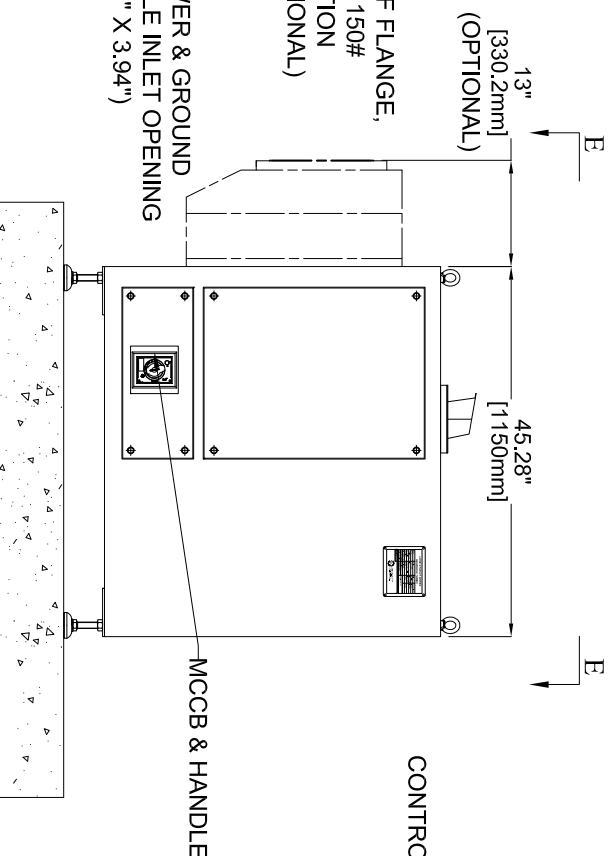

**VIEW "C"**  
(FRONT SIDE)

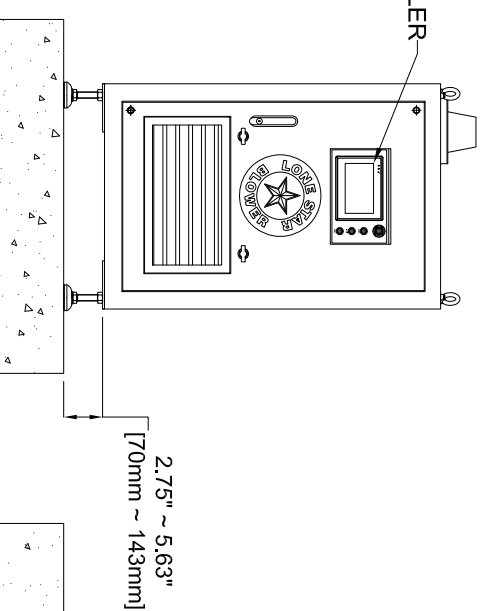

**VIEW "D"**  
(RIGHT SIDE)

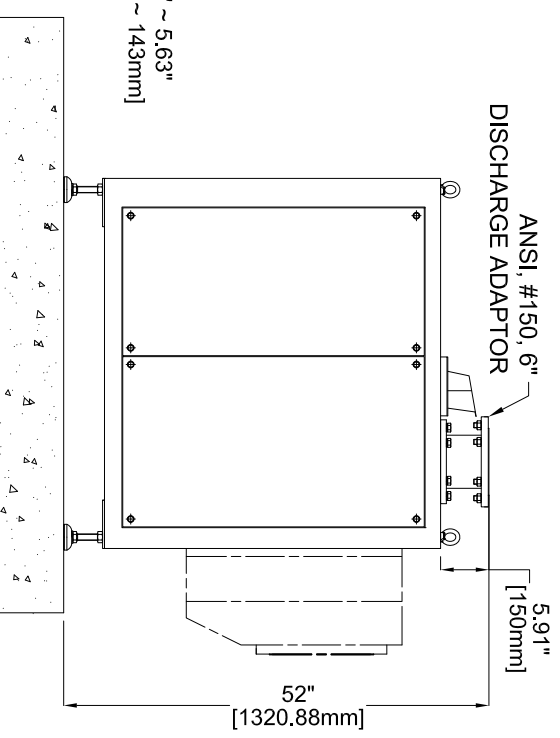

ALL DIMENSIONS ARE SUBJECT TO CHANGE WITHOUT NOTICE.  
PLEASE CONSULT WITH LONE STAR PRIOR TO DESIGNING AROUND PARTICULAR EQUIPMENT.

MODELS	WEIGHT
MAX50-C060-C080-C100 LOUVER	840 LBS (380 KG)
MAX50-C060-C080-C100 FLANGED INTAKE	940 LBS (425 KG)

UNLESS OTHERWISE SPECIFIED  
DO NOT SCALE

LONE STAR BLOWER PROPRIETARY RIGHTS ARE INCLUDED HEREIN. THIS INFORMATION MAY NOT BE COPIED, TRANSFERRED, OR DISCLOSED, EXCEPT AS AUTHORIZED BY LONE STAR BLOWER.

DRAWING IS FOR REFERENCE ONLY  
UNLESS SPECIFIED AS RELEASED.



TITLE  
DT SERIES

BLOWER MAX50-C060-C100

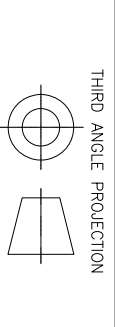

APPROVALS	
DRAWN	JMC
CHECK	
ENGINEER	
MANUFACTURING	
CONTROL	
APPROVED	

SIZE	CAGE CODE	DWG NUMBER	REV
A	-	MAX50-C060-C100	0

REVISION HISTORY		
REV	DESCRIPTION	DATE

DATE	APPROVED